

National 5

**Graphic
Communication**

**CAD Modelling
Solutions**

Question 1—Bird House

1. Create a 2D sketch and draw the following shape using the line tool. Once drawn, use the dimension tool to dimension it as shown.

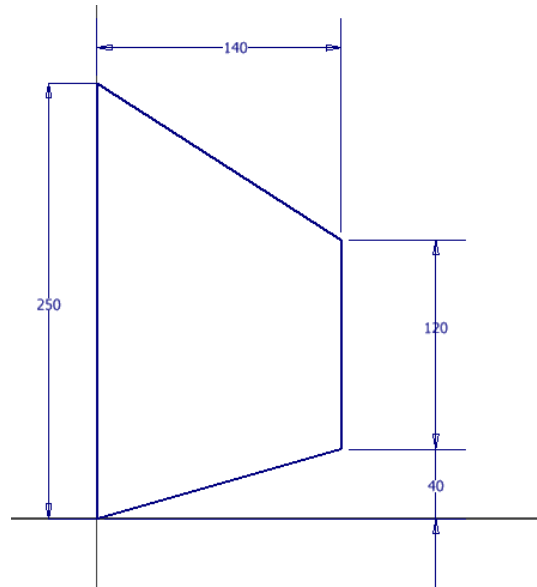

2. Finish the sketch and extrude by 180mm.

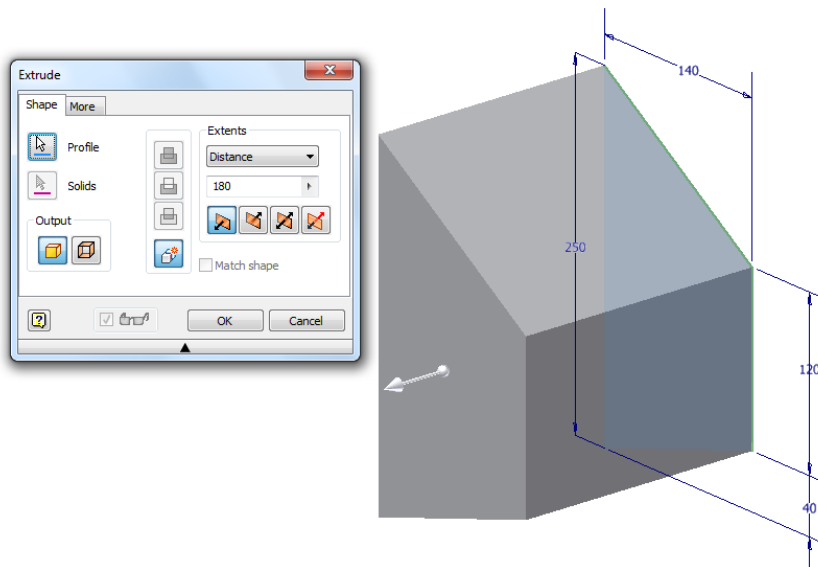

3. Shell the bird house 10mm, removing the top surface.

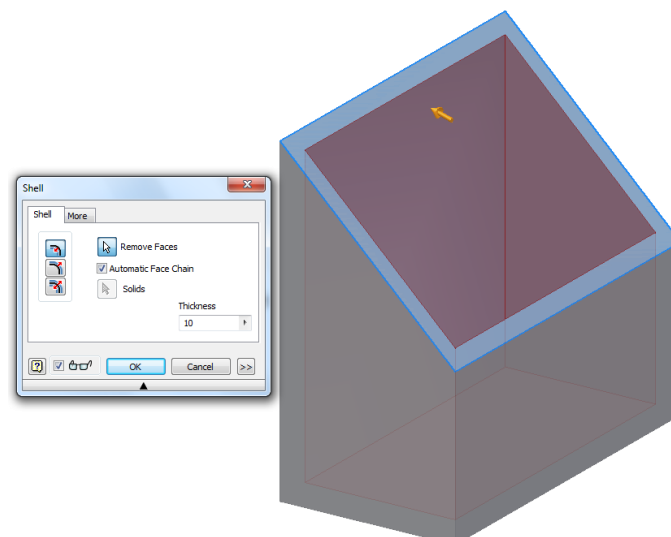

4. Sketch on the front surface of the bird house. Draw a circle $\varnothing 45\text{mm}$ in the centre of the face.

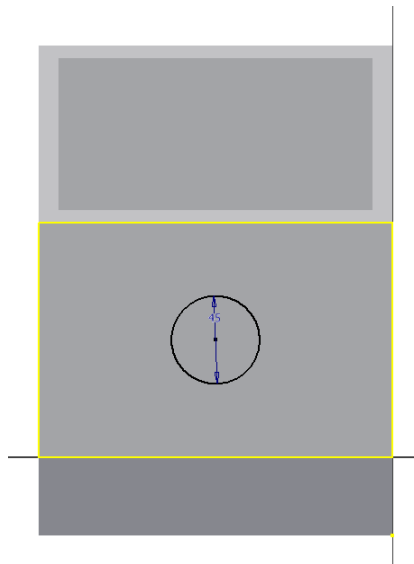

5. Finish the sketch and extrude the circle by subtraction 10mm.

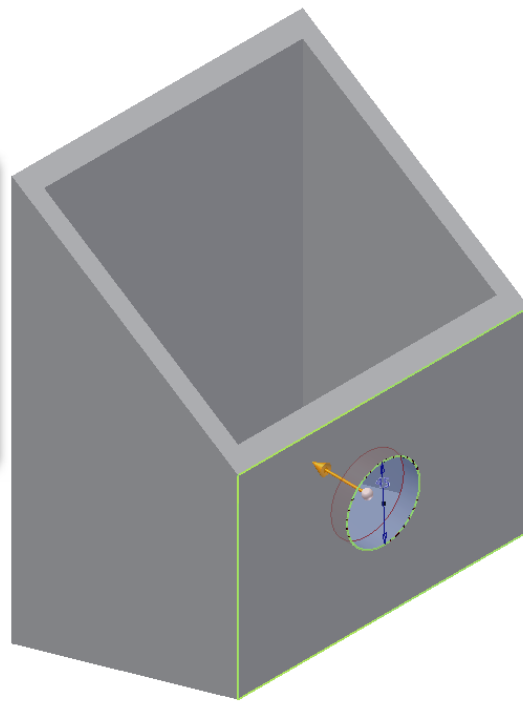
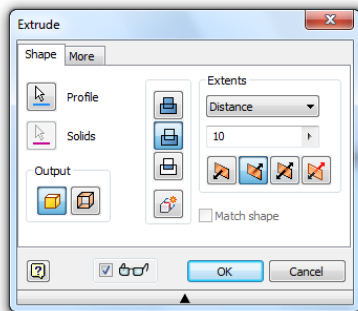

Question 2– Garden Planter

1. Create a sketch of a square 300mm.

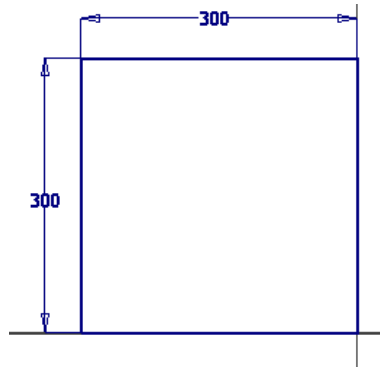

2. Finish the sketch and create a work plane. Offset the work plane 800mm.

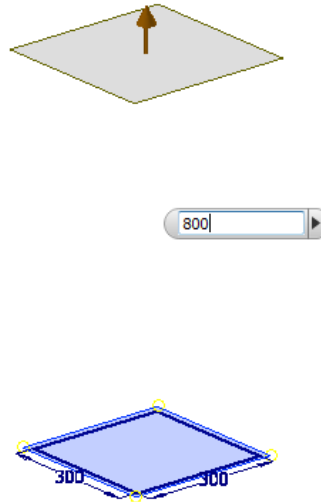

3. Project the geometry of the original square and offset it. Dimension it to 600mm and finish the sketch.

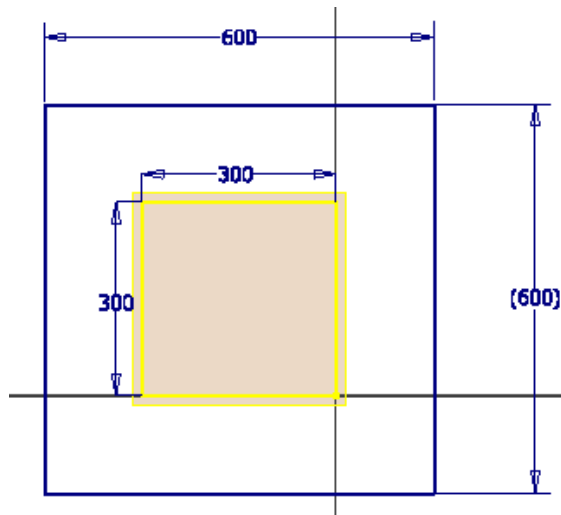

4. Use the loft tool and select the two squares.

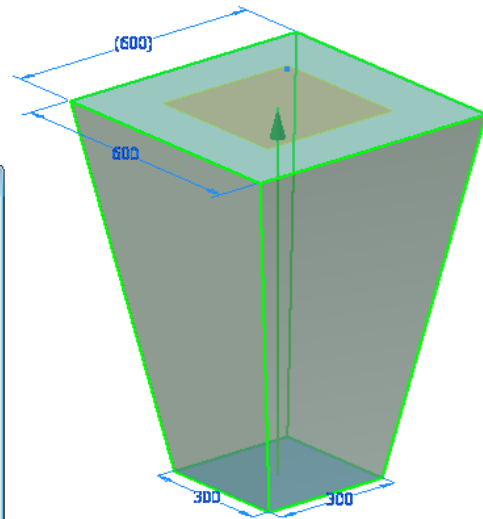
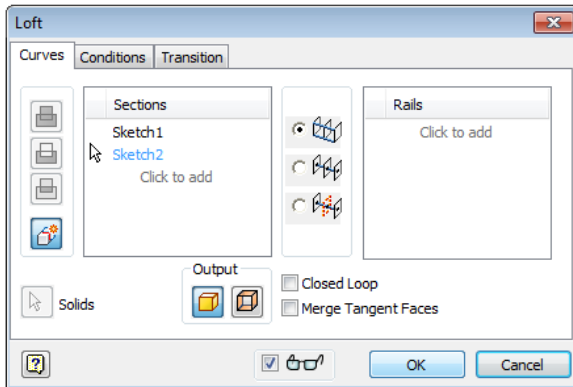

5. Shell the planter 3mm, removing the top surface.

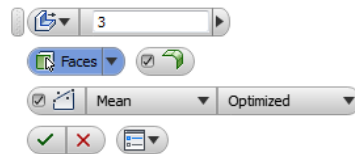
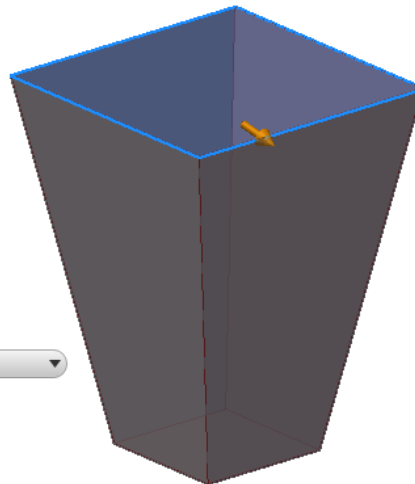
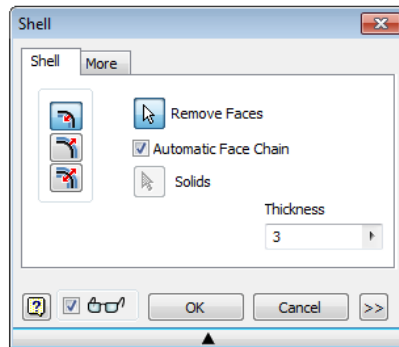

Question 3– Wine Glass

1. Create the sketch shown below using the line and arc tools.

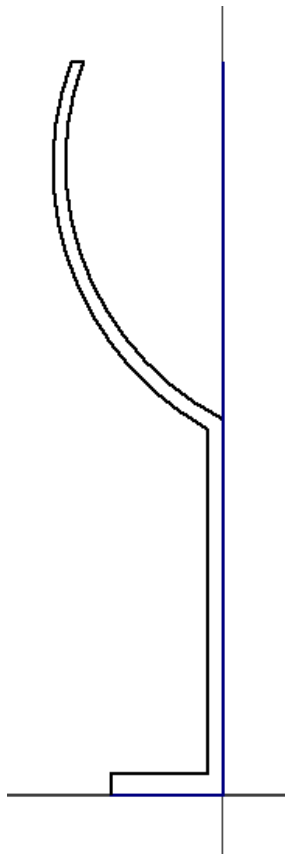

2. Use the revolve tool and revolve the sketch 360° around the centre line.

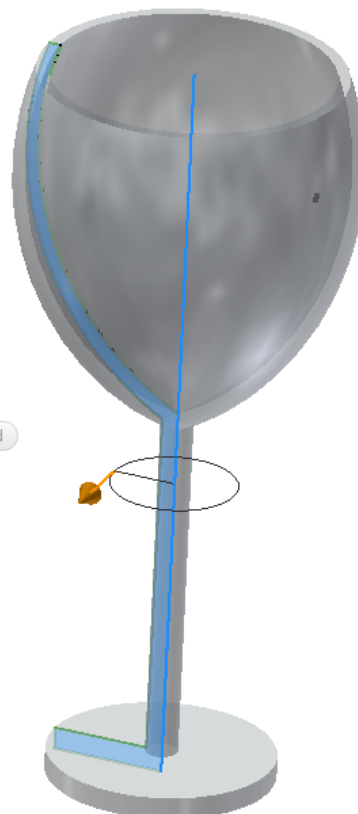
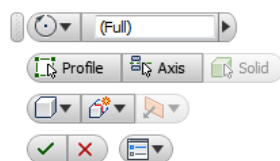
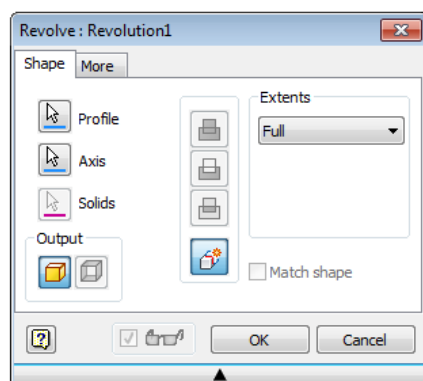

3. Add a small fillet to the edges of the glasses.

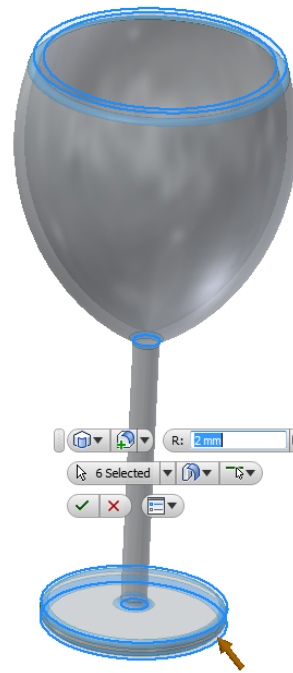
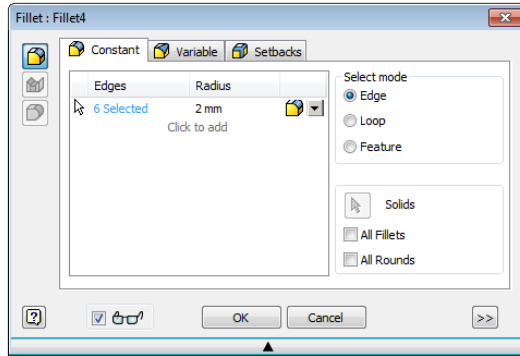

Question 4—skateboard Wheel

1. Sketch a circle diameter 65mm.

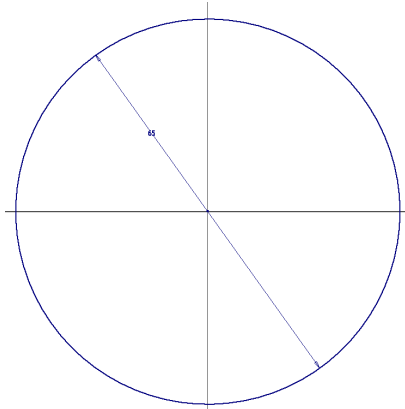

2. Finish the sketch and extrude the circle 22mm.

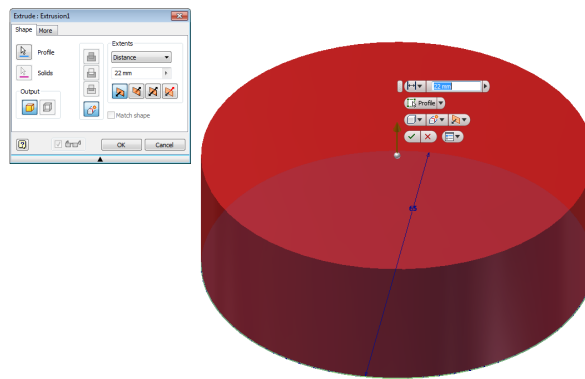

3. On the top surface of the cylinder, sketch a circle diameter 16mm.

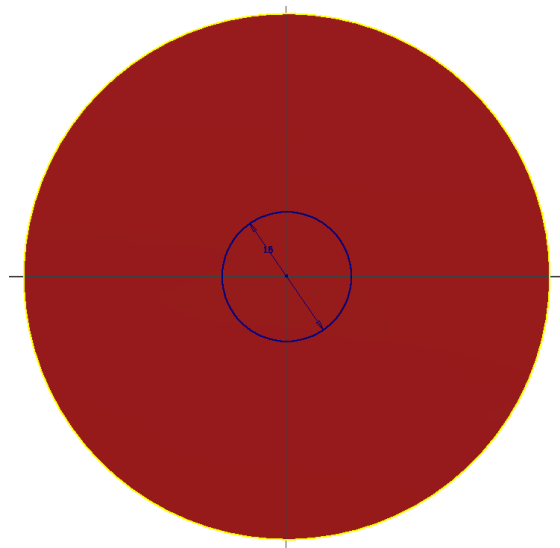

4. Finish the sketch and extrude the circle by subtraction 10mm.

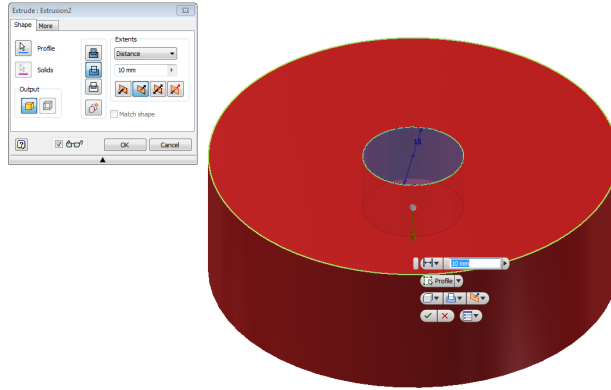

5. On the opposite face sketch a circle in the centre diameter 8mm.

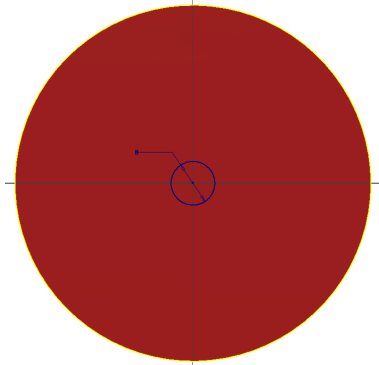

6. Finish the sketch and extrude by subtraction through all.

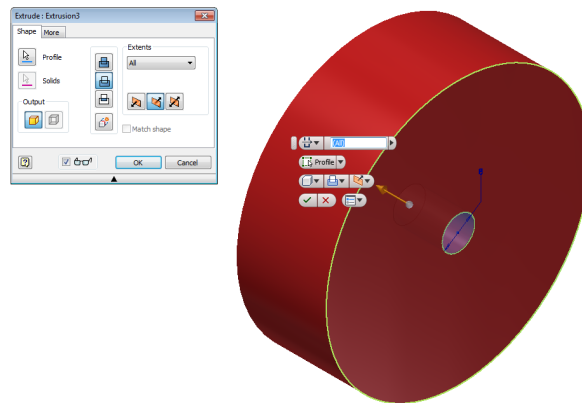

7. Use the fillet tool to add an 8m radius to the outside edges.

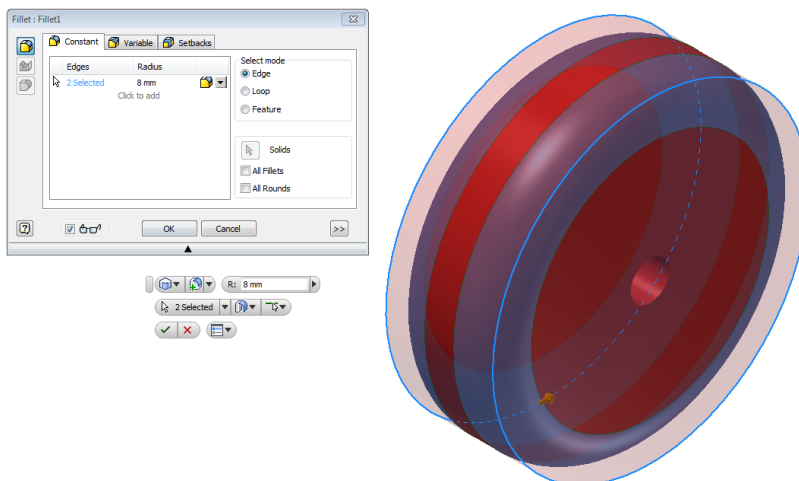

Question 5—Bracket

1. Sketch the profile shown below and dimension it as shown.

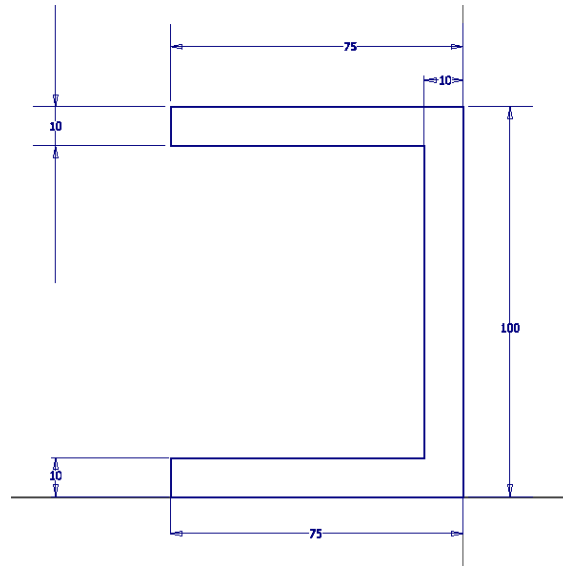

2. Extrude the profile 50mm.

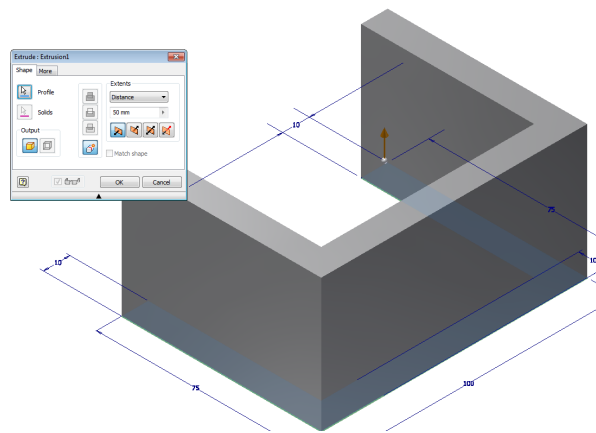

3. Sketch on the top surface. Draw a circle diameter 30mm. Dimension it 25mm from the left and the bottom edges.

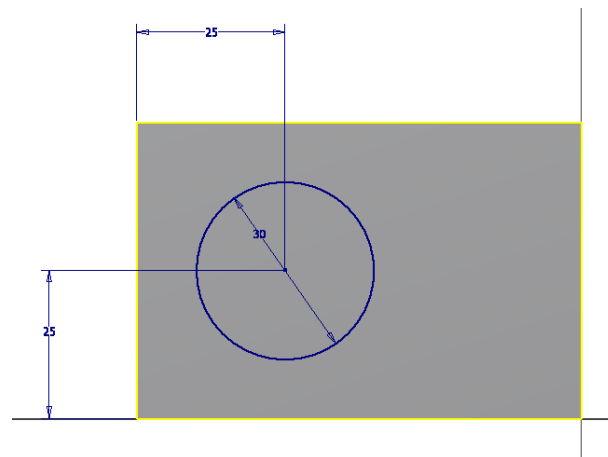

4. Extrude by subtraction through all material.

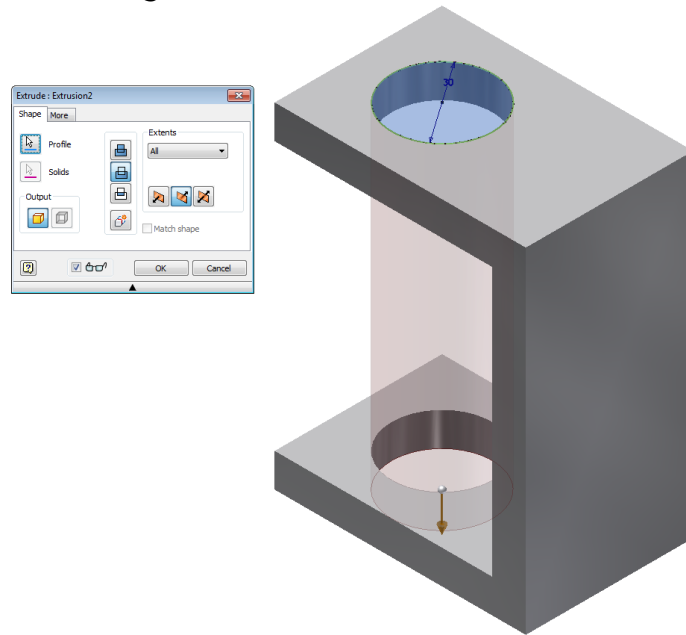

5. Select the fillet tool and select the edges shown. Add a 25mm radius to each of the four edges shown.

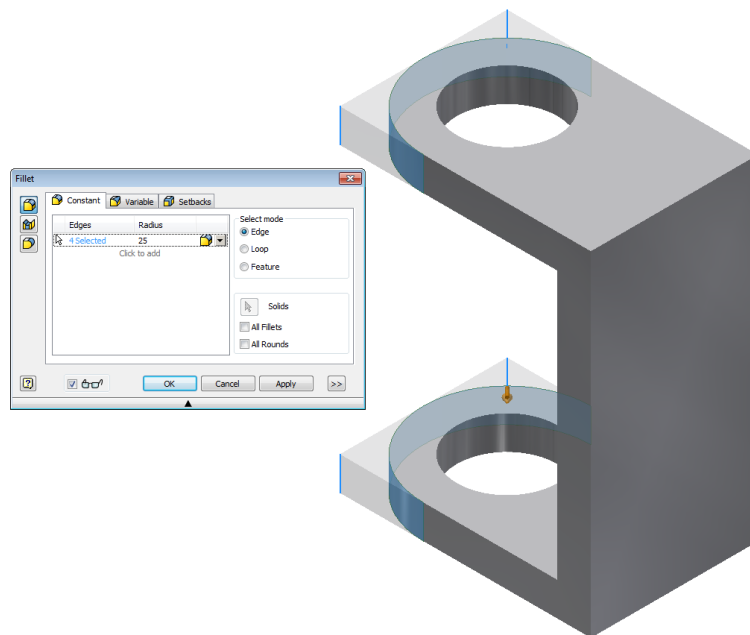

Question 6—Bin

1. Sketch a circle and extrude it to make a cylinder.

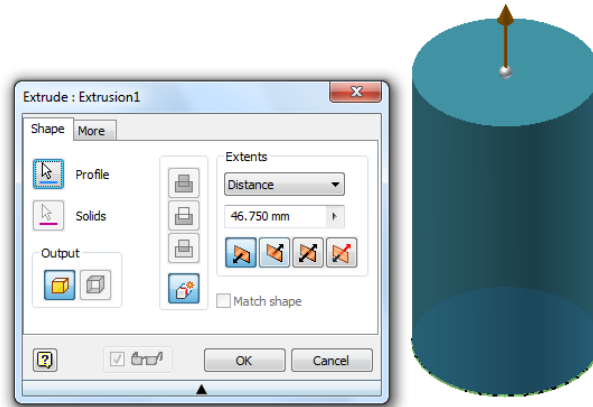

2. Create a work plane through the centre of the cylinder.

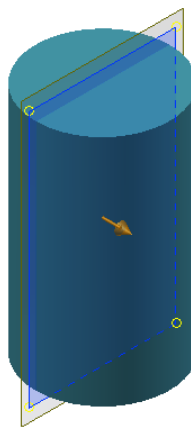

3. Sketch on the work plane and use the line tool to draw a profile like the one shown below.

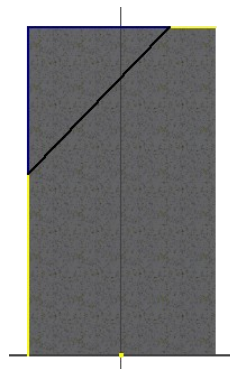

4. Finish the sketch and extrude by subtraction symmetrically through all material.

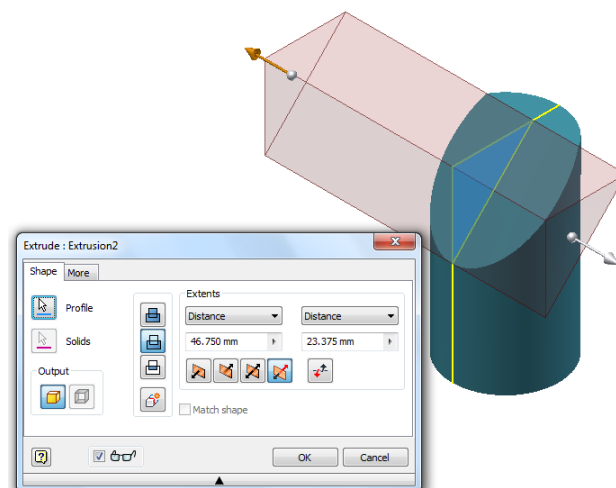

5. Shell the shape to a suitable thickness without removing any faces.

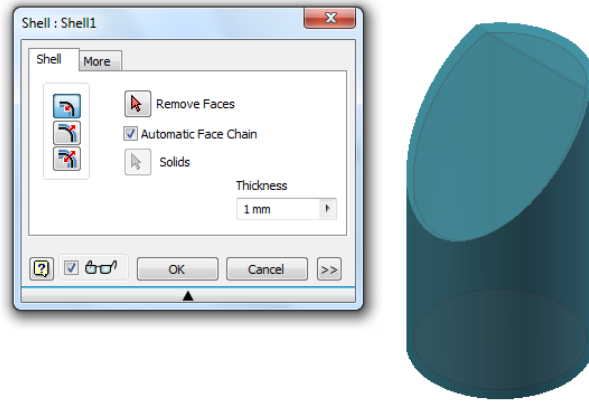

6. Sketch a circle on the sloping surface.

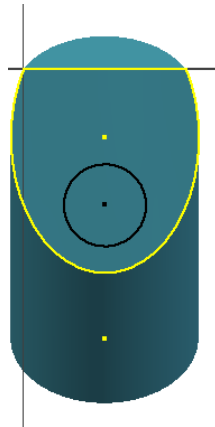

7. Finish the sketch and extrude the circle by subtraction into the shape without going all the way through.

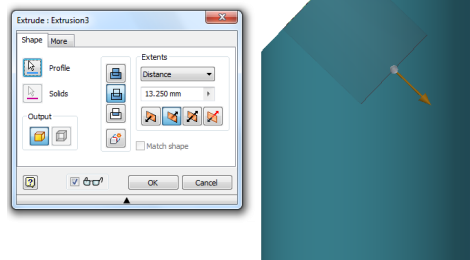

Question 7—Chair Arm

1. Sketch a circle diameter 80mm. Draw a small vertical line and dimension it 500mm away from the centre of the circle.

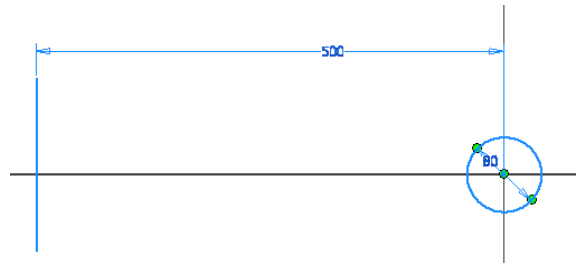

2. Select the revolve tool. Select the circle as the profile and the line as the axis and revolve 180°.

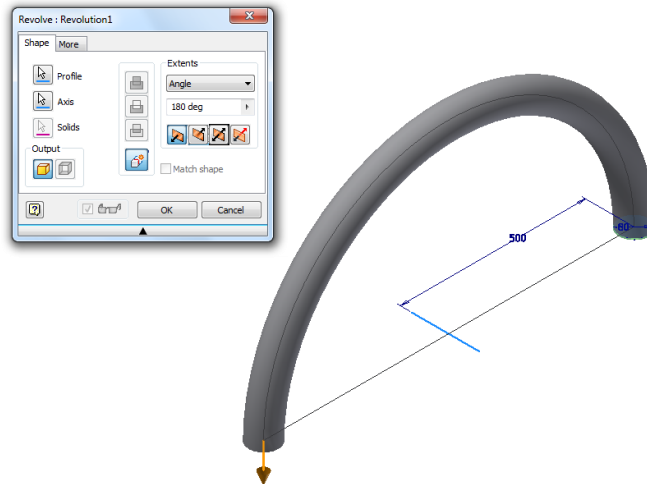

3. Create a work plane outside the revolved shape as shown.

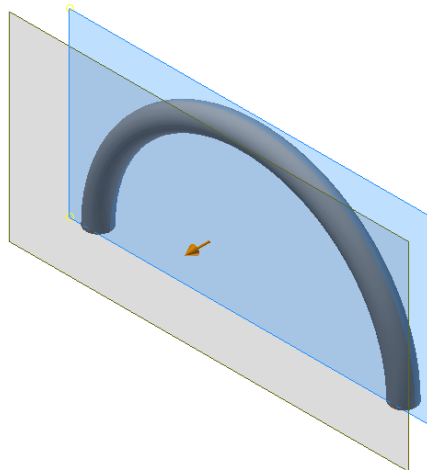

4. Sketch on the work plane and use the line tool to draw the profile shown.

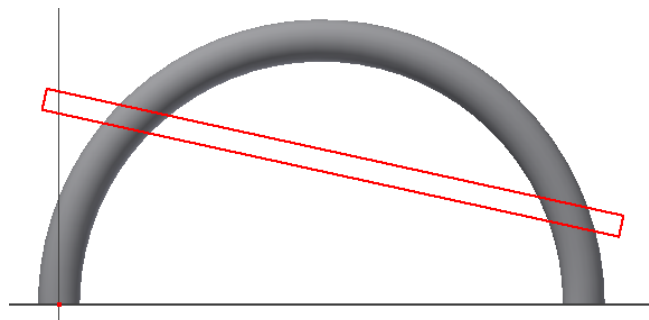

5. Finish the sketch and extrude the profile by subtraction into the arm of the chair by a suitable amount.

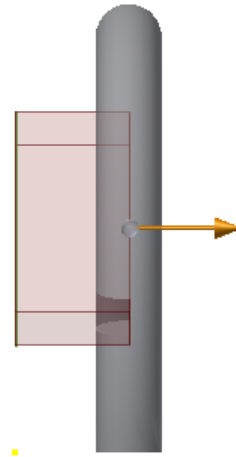
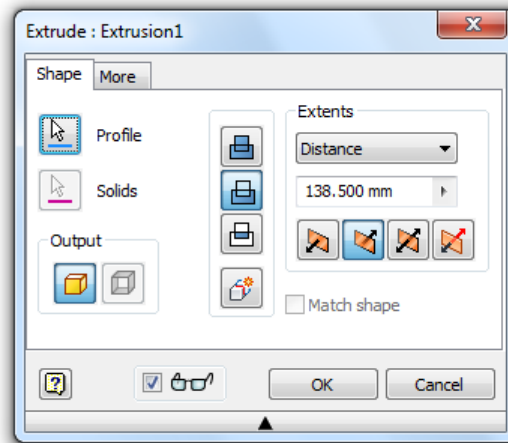

Question 8—Earphone Cone

1. Use the line tool to sketch the profile shown below.

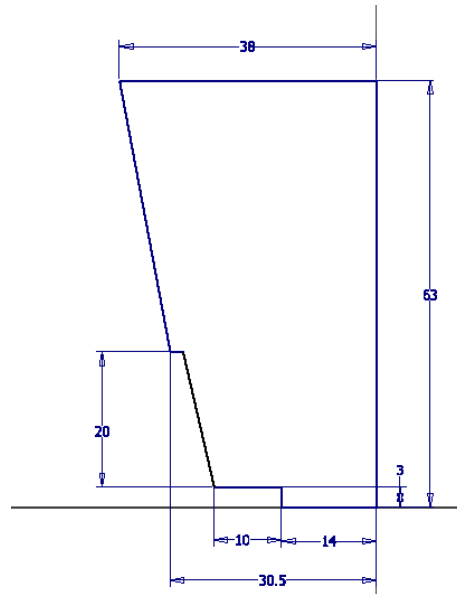

2. Use the revolve tool to revolve the profile 360° around the centre line.

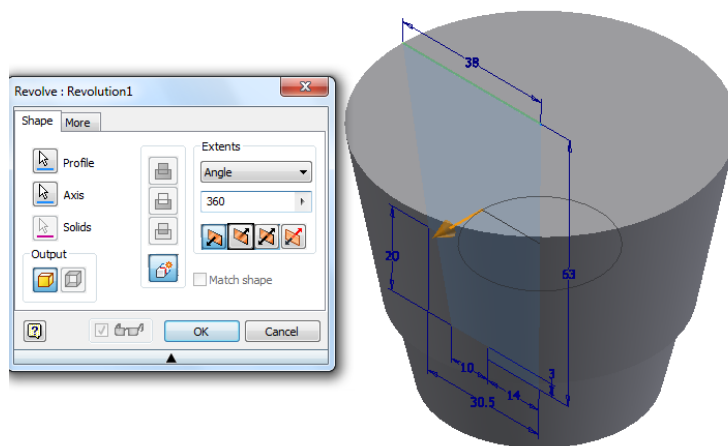

3. Create a work plane through the centre of the shape.

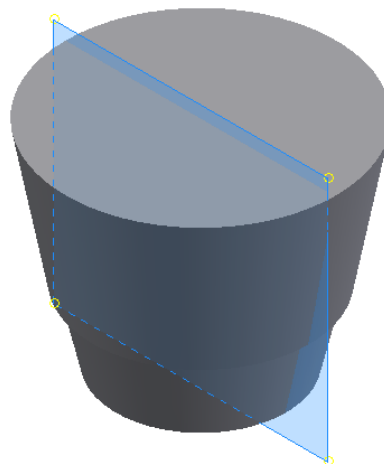

4. Sketch on the work plane and use the line tool to draw the shape shown below.

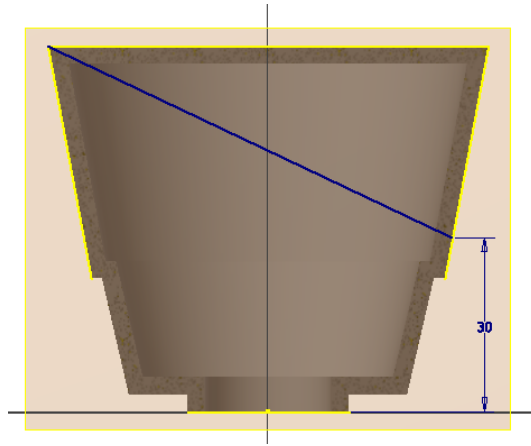

5. Select the extrude tool and extrude the shape by extrusion symmetrically through all material.

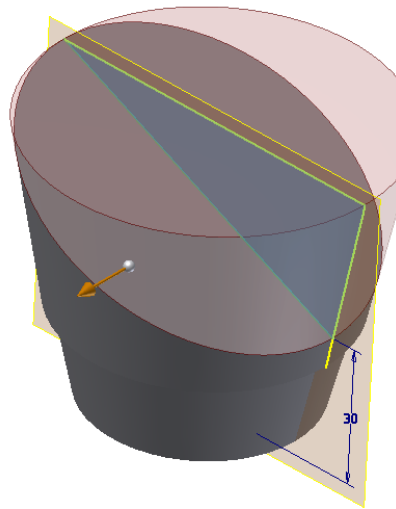
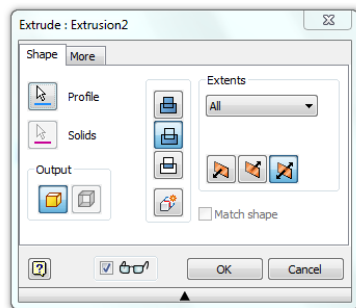

6. Shell the shape 3mm, removing the bottom surface.

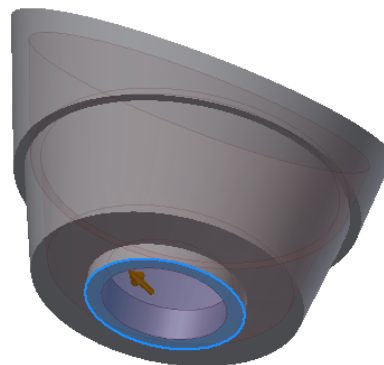
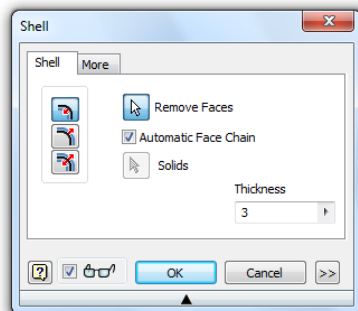

Question 9 - Wall Bracket

1. Create a 2D sketch and draw the following shape using the line tool. Once drawn, use the dimension tool to dimension it as shown.

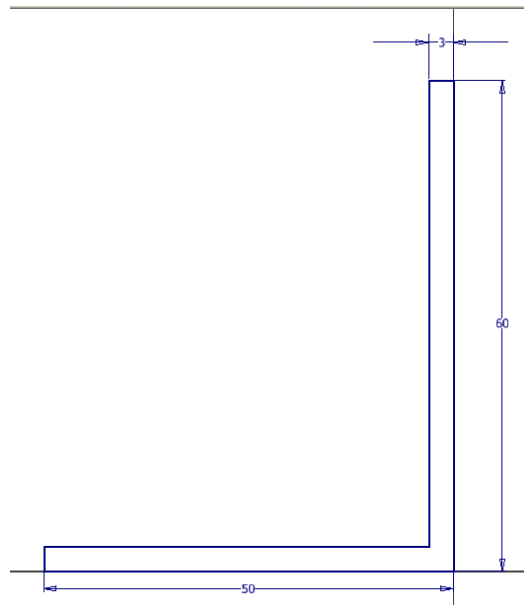

2. Finish the sketch and extrude by 40mm.

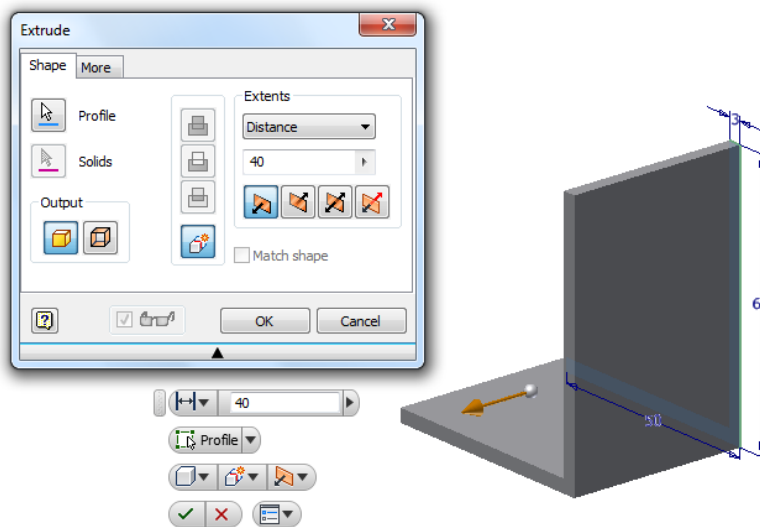

3. Create a new work plane through the middle of the bracket.

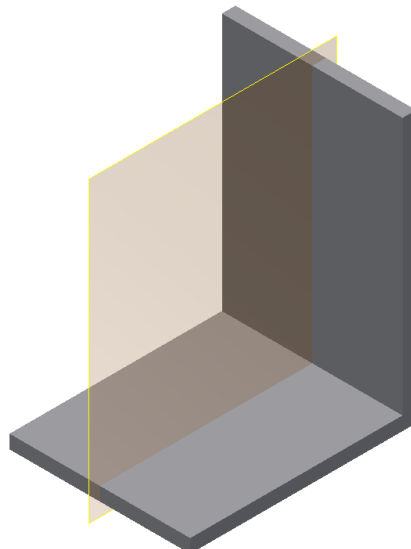

4. Create a new 2D sketch on this work plane. Use the line tool to draw a triangle and dimension it as shown.

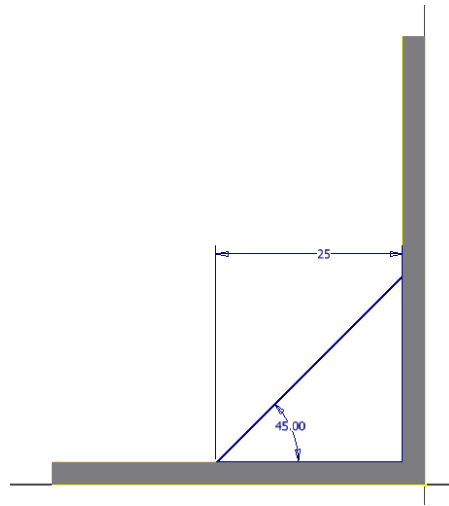

5. Finish the sketch and extrude the shape symmetrically 5mm each way.

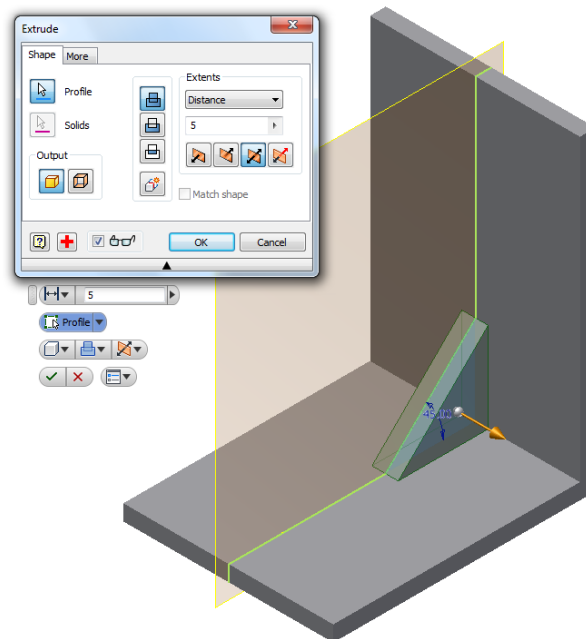

6. Create a new sketch on the upright surface and draw a 4mm circle as shown. Use the dimension tool to position it as shown.

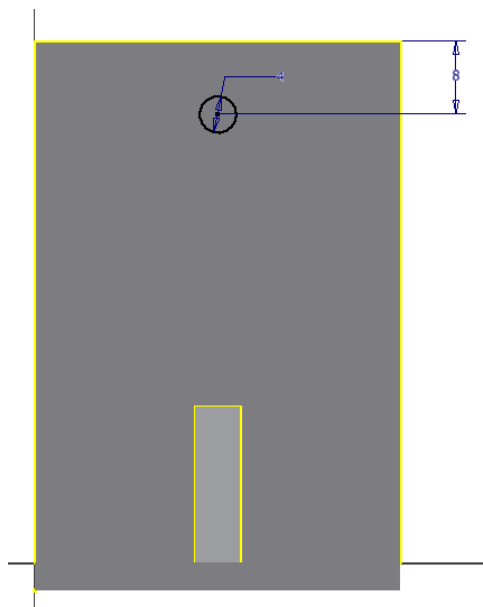

7. Finish the sketch and extrude the circle by subtraction all the way through the material.

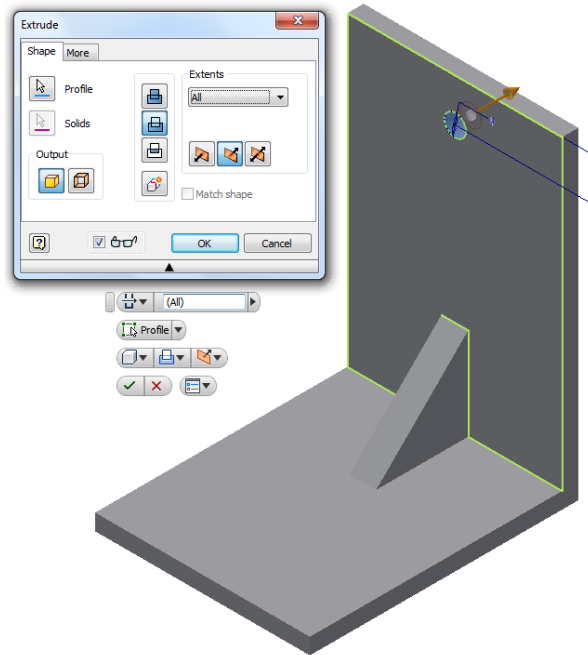

8. Select the bottom of the bracket and create a new sketch. Draw a circle 4mm and position it as shown.

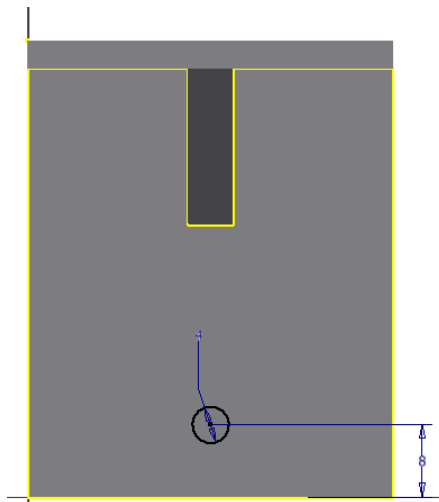

9. Finish the sketch and extrude the circle by subtraction all the way through the material.

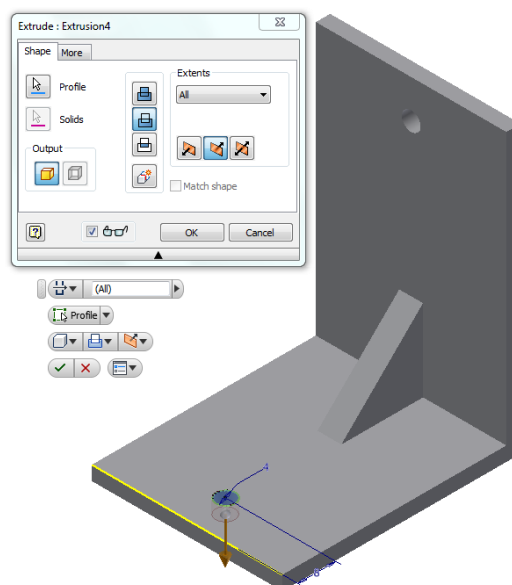

Question 10—Barbecue

1. Create a sketch using the line tool to make a half profile like the one shown below.
2. Revolve the profile 360o around the centre line.

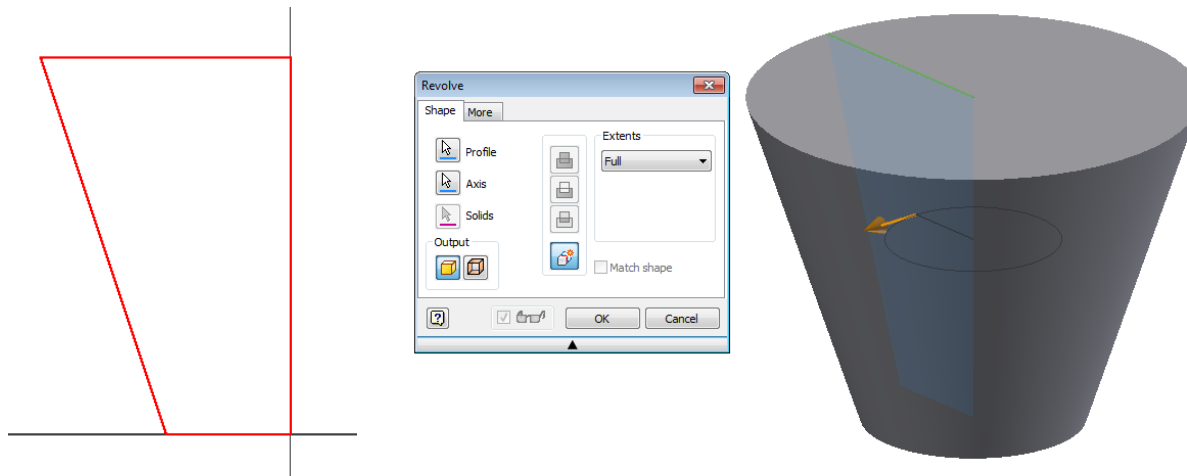

3. Create a work plane through the centre of the object.
4. Create a new sketch on the work plane and use the line tool to create the profile as shown.

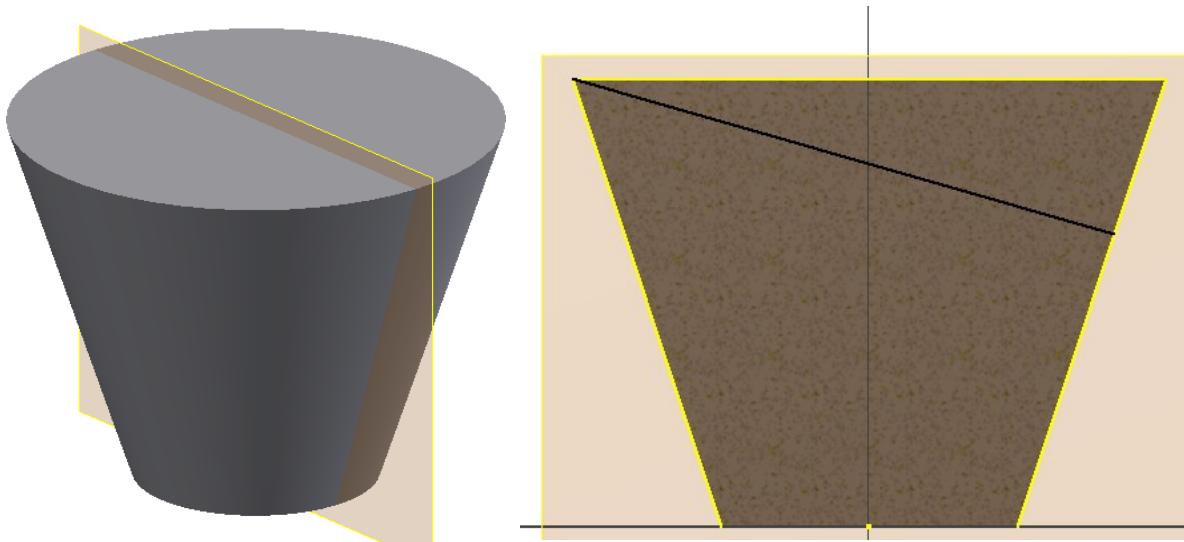

5. Extrude the profile by subtraction symmetrically through all material.
6. Shell the object to a suitable thickness, removing the top sloping surface.

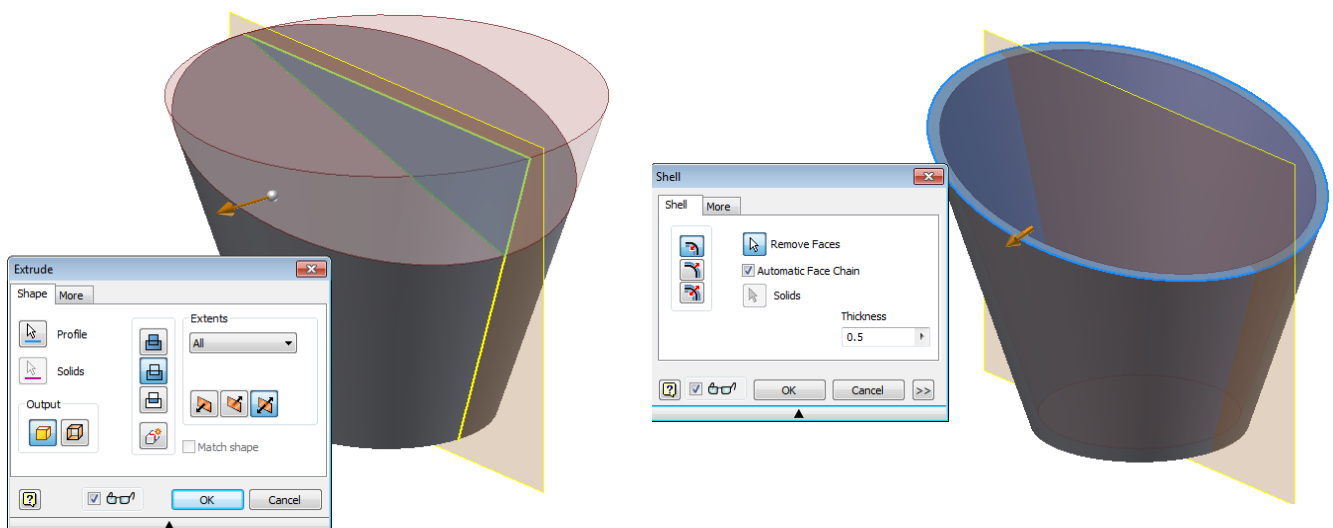

Question 11—Hoover attachment

Method 1—Revolve

1. Sketch the profile shown using the line tool.
2. Use the revolve tool and revolve the profile 360° around the centre line.

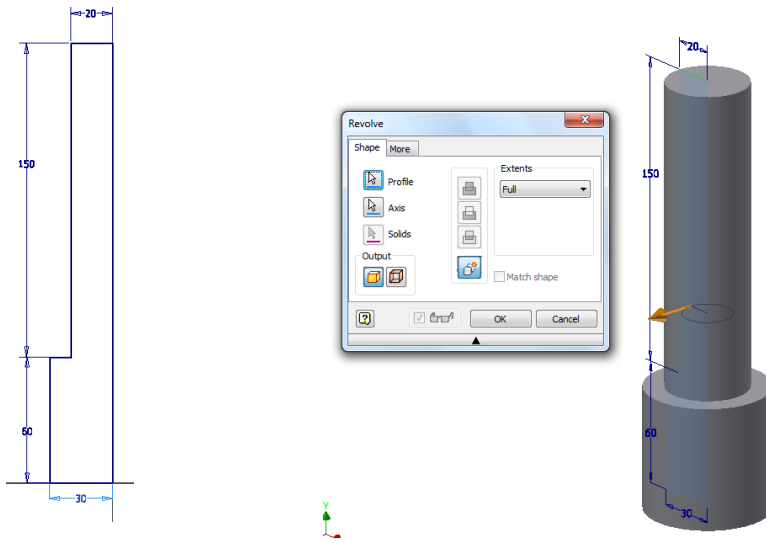

Method 2—Extrude

1. Sketch a circle diameter 60mm.
2. Extrude the circle 60mm.

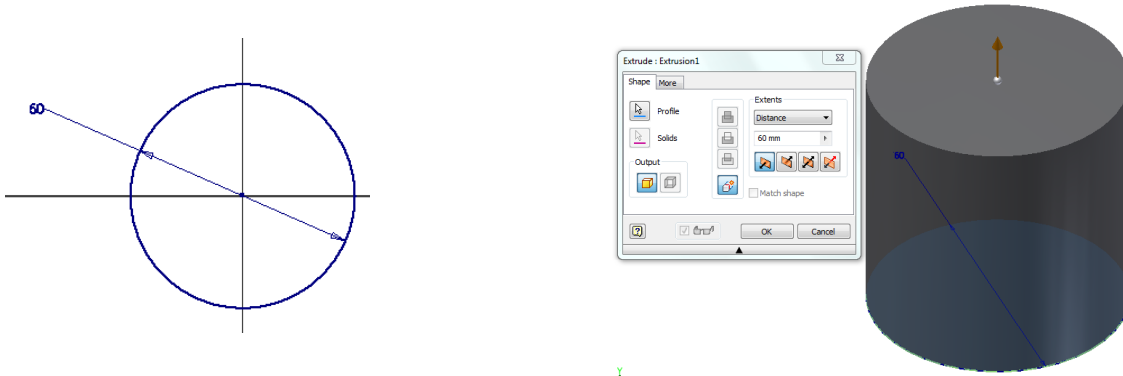

3. Sketch on the top surface of the cylinder and draw a circle diameter 40mm.
4. Extrude the circle 150mm.

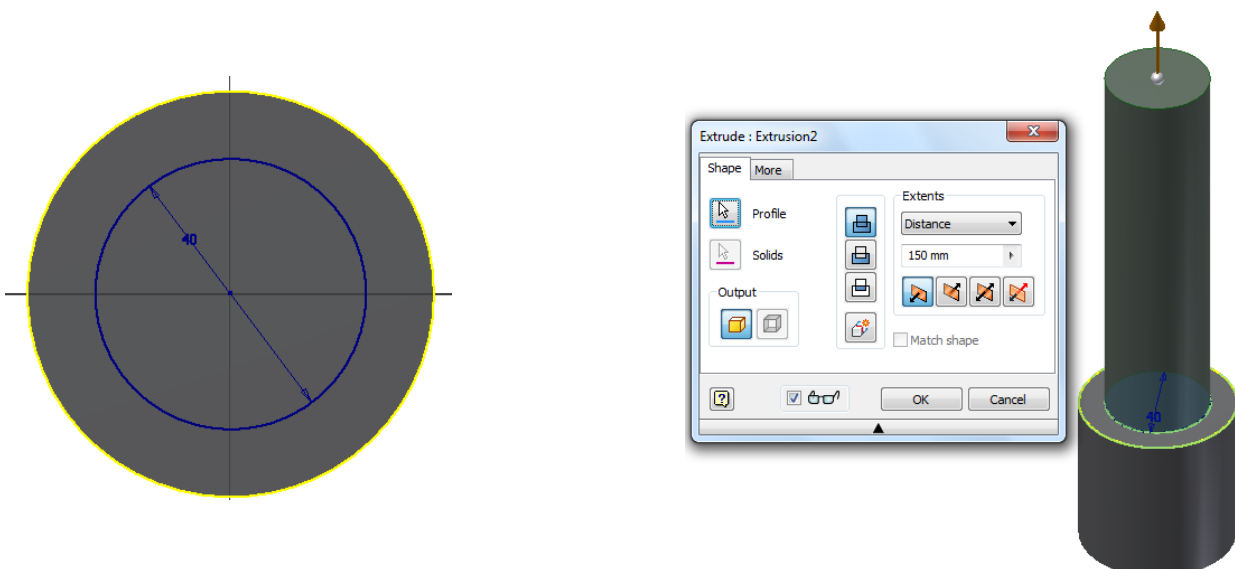

5. Create a work plane through the centre of the object.
6. Sketch on the work plane and use the line tool to draw the profile as shown.

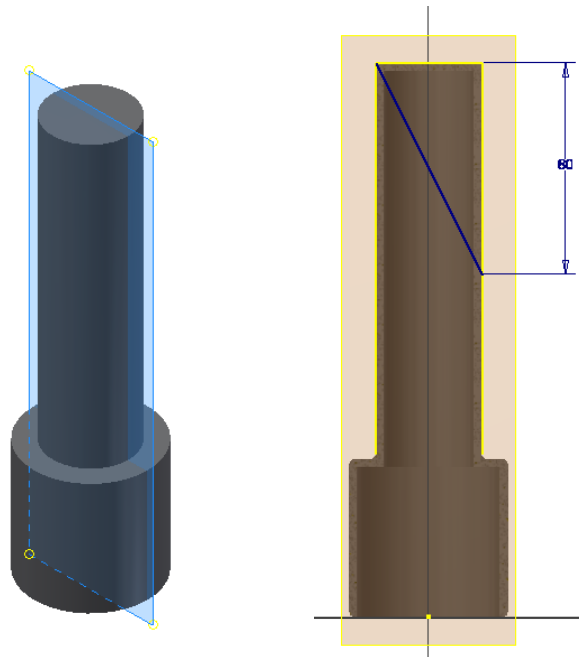

7. Extrude the profile by subtraction symmetrically through all material.

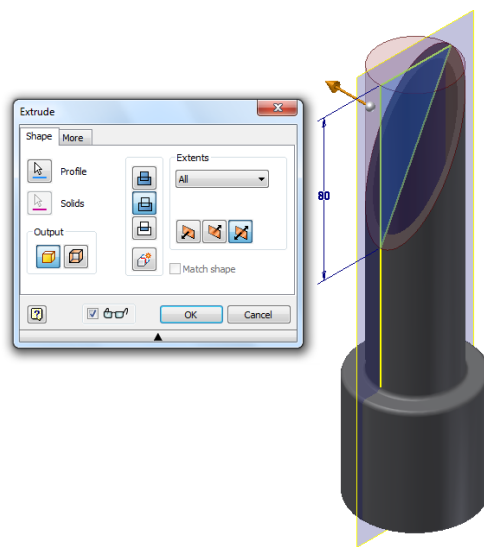

8. Shell the shape 3mm, removing both the bottom and sloping faces.

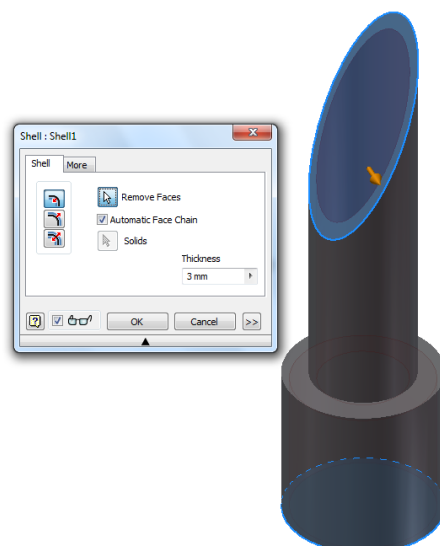

9. Use the fillet tool to add a small 2mm radius to the edges shown.

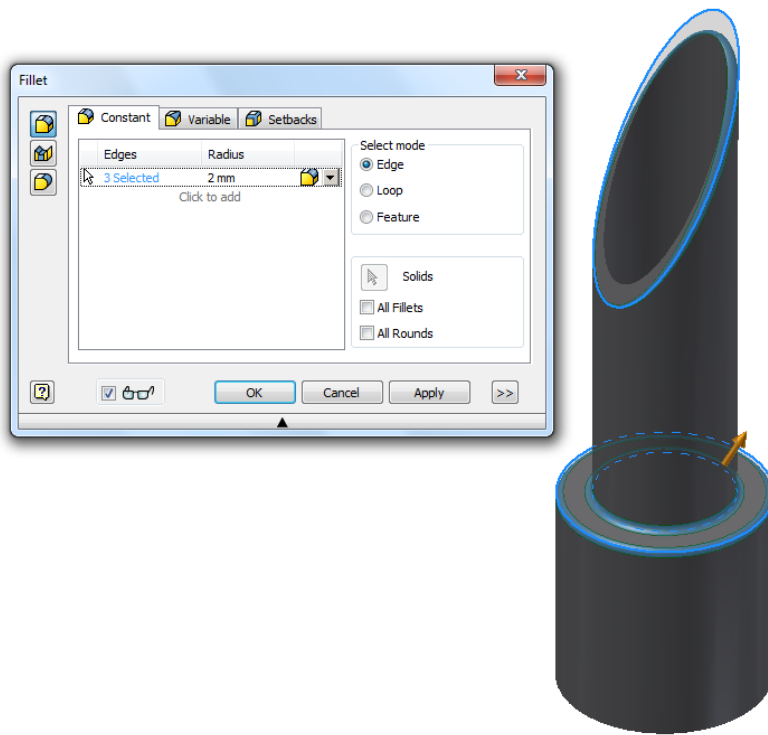

Question 12– Till Roll Holder

1. Create a sketch and use the line tool to create the profile shown below
2. Extrude the profile 50mm.

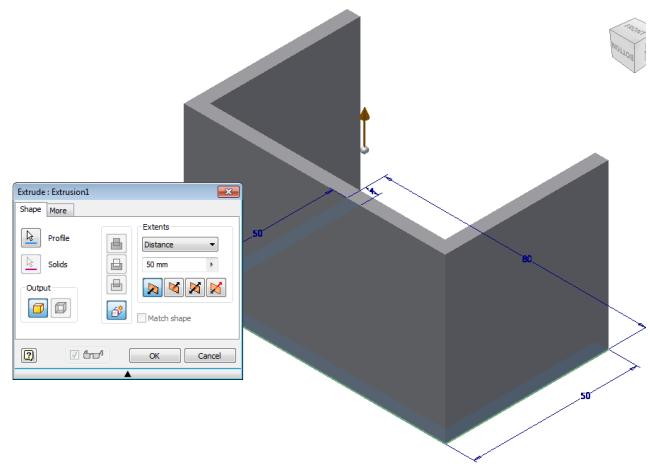
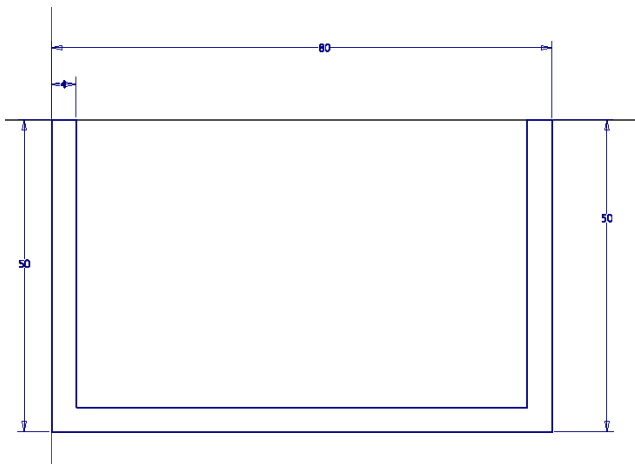

3. Sketch a circle diameter 25mm on the bottom surface.
4. Finish the sketch and extrude 50mm.

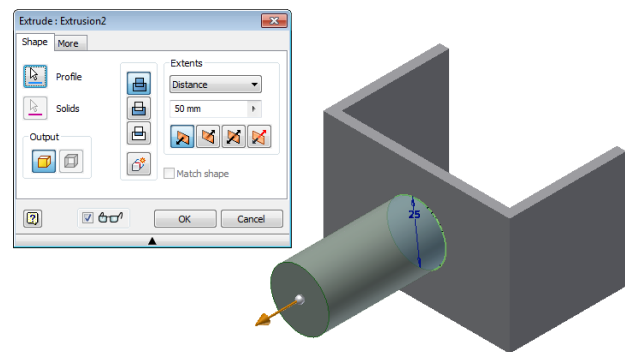
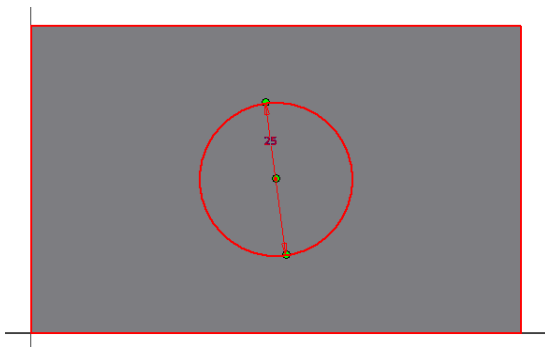

5. Use the fillet tool to add a 20mm radius to the edges shown.

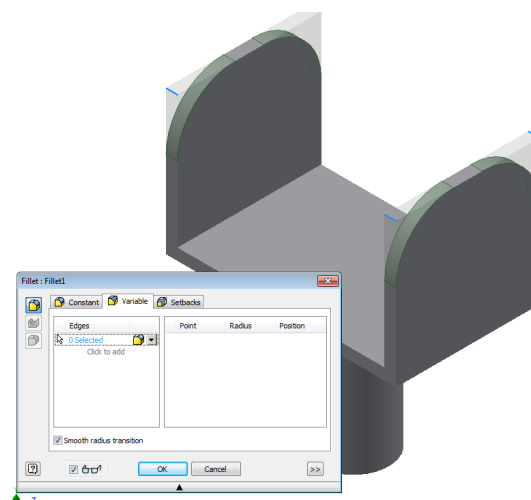

6. Create a sketch on one of the inside edges and use the rectangle tool to make the profile shown.
7. Finish the sketch and extrude the rectangle by subtraction 2mm.

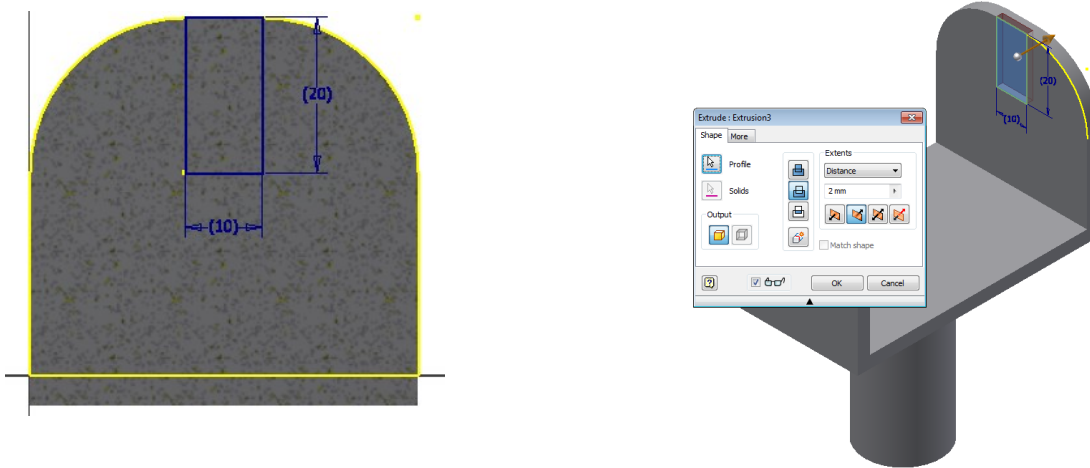

8. Create a work plane through the centre of the object and select the mirror tool. Select the extruded rectangle as the feature and the work plane as the mirror plane.

